



*C 300 split*

# LIST OF THE EXPLODED VIEWS



*SHELL ASSY*

*COOLING SYSTEM*

*HYDRAULIC CIRCUIT*

*ELECTRIC PARTS*

Rev. 0 - 04/05/2012



# C 300 split

## SHELL ASSY

Ref.	Spare Description	Code
1	Top	221283
2	Rear Panel	21370
3	Right Side Panel	22735
4	Front Panel	C22744
5	Front Panel with hole	221282
6	Left Side Panel	221284
7	Left Side Panel	22736

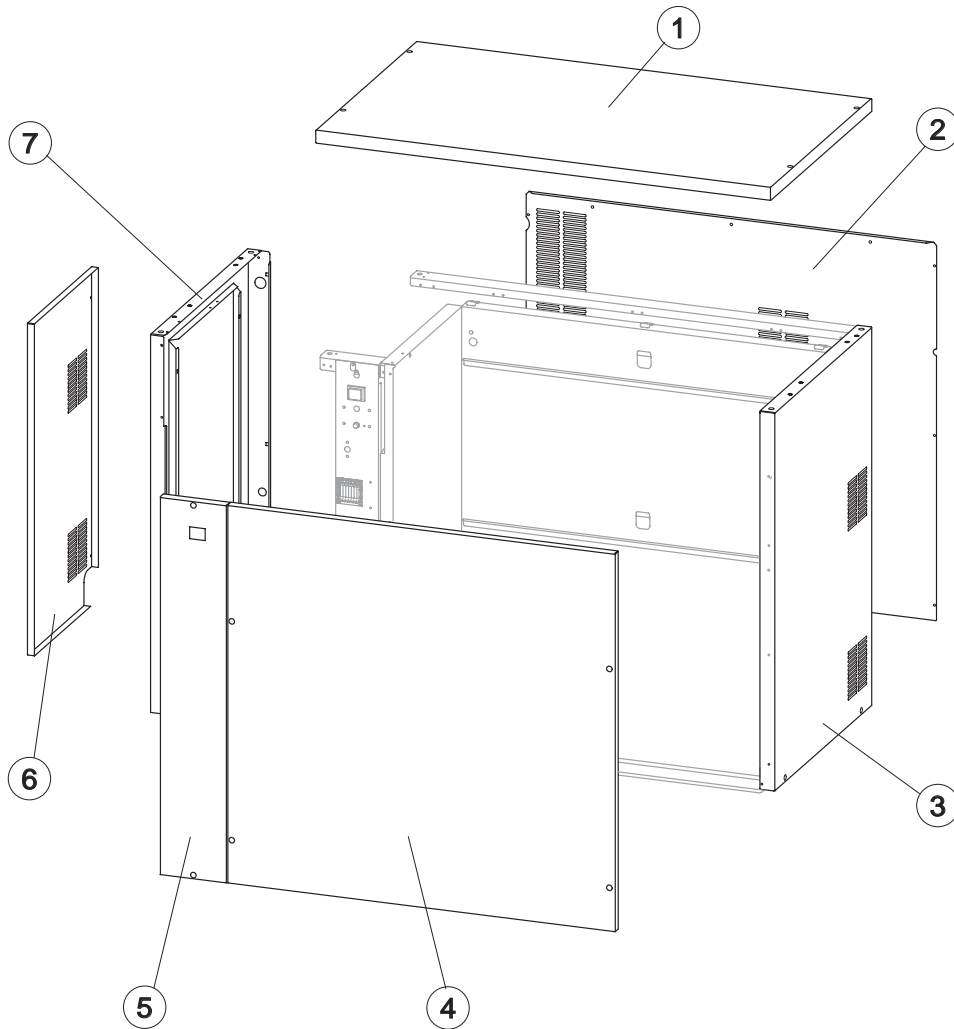

Rev. 0 - 04/05/2012



# C 300 split

# COOLING SYSTEM

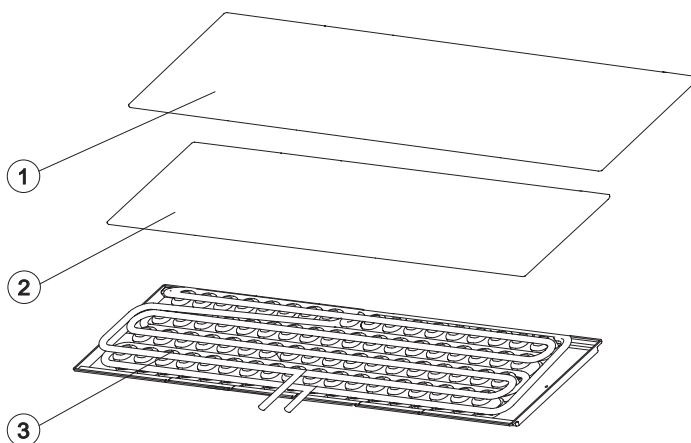

Ref.	Spare Description	Code
1	Upper Evaporator Cover Panel	10439
2	Evaporator Cover Panel	10058
3	Evaporator	See Table
4	Expantion Valve	201006
5	Evaporator Pressure Regulating Valve	20977
6	Hot Gas valve Coil	23091
7	Hot Gas valve Body	20409
8	Cranckase Pressure Regulating Valve	201007

Rev. 0 - 04/05/2012

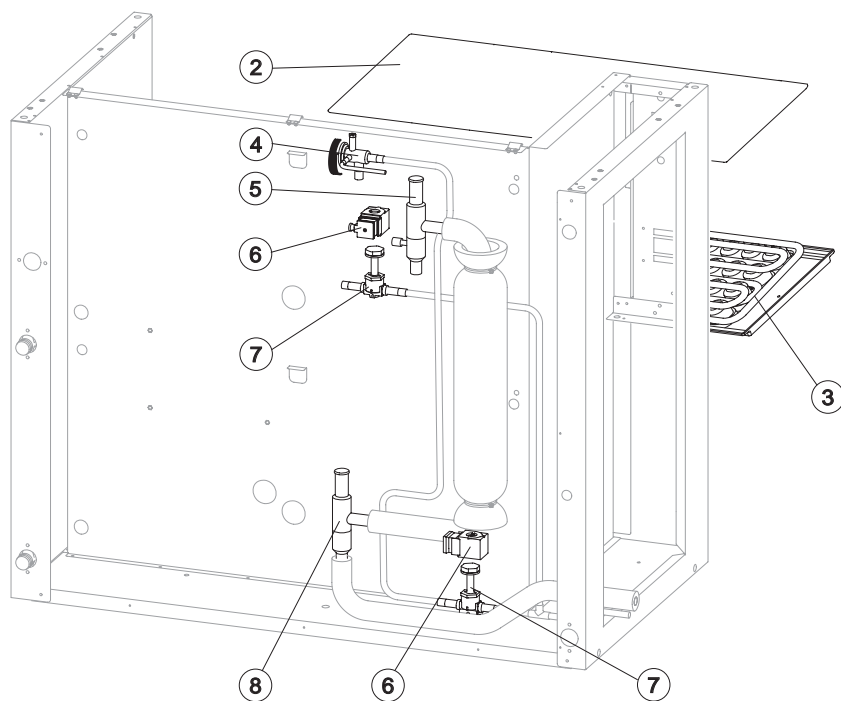

### Ref. 3 - Evaporator

Kind of Cube	Code
18 g. (Standard)	D10214
33 g.	D10092
13 g.	D10126
42 g.	D10477
60 g.	D10555



# C 300 split

# HYDRAULIC CIRCUIT

Rev. 0 - 04/05/2012

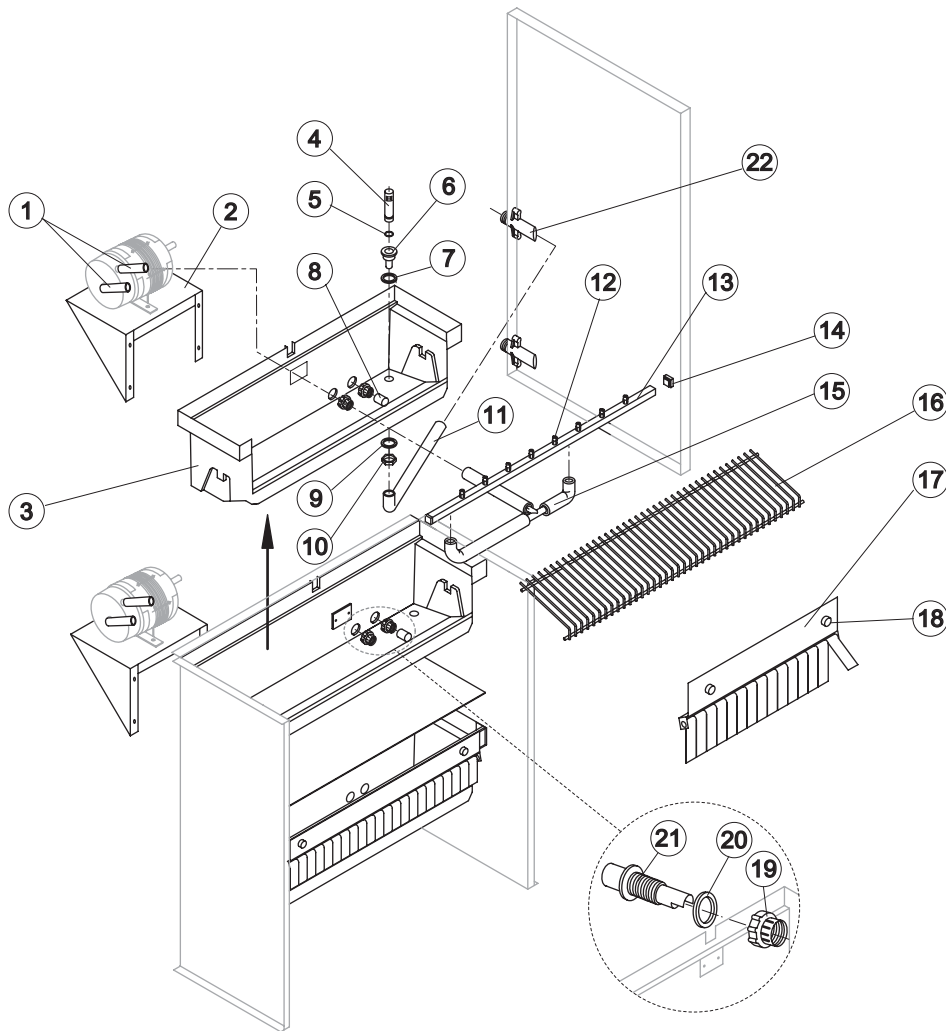

Ref.	Spare Description	Code	
1	Pump Suction/Delivery Pipe	13150	
2	Pump Support Plate	21277	
3	Inner Basin	10440	
4*	Overflow pipe	10133	
5*	OR Gasket for Overflow Pipe	20233	
6	Water Outlet Nipple	10471	
7	Silicone Gasket	13006	
8*	Pump Suction Filter	20005	
9	Semirigid polyethylene	13007	
10	Bin Discharge Nut	10096	
11	Water Discharge Pipe	13054	
12	Sprayer	D20002	
13*	Sprayer Bar Assembly	See Table	-
14	Sprayers Bar Plug	10012	
15	Sprayers Bar Pipe Connection	C13036	
16	Ice Cube Slide	See Table	-
17	Flag Support Assy	C22134	
18	Fixing Screw	20009	
19	Fittings Locking Ring	10405	
20	Gasket for Pump Suction/ Delivery pipes	13143	
21	Fittings Locking Ring	10424	
22	Discharge Manifold	C10415	

### Ref. 13\* - Sprayer Bar ass.

Kind of Cube	Code
18 g. (Standard)	C20144
33 g.	C20157
13 g.	C20200
42 g.	C20157
60 g.	C20941

### Ref. 16 - Ice Cube Slide

Kind of Cube	Code
18 g. (Standard)	D12022
33 g.	D12033
13 g.	D12040
42 g.	D12033
60 g.	D12084



# C 300 split

## ELETTRIC PARTS

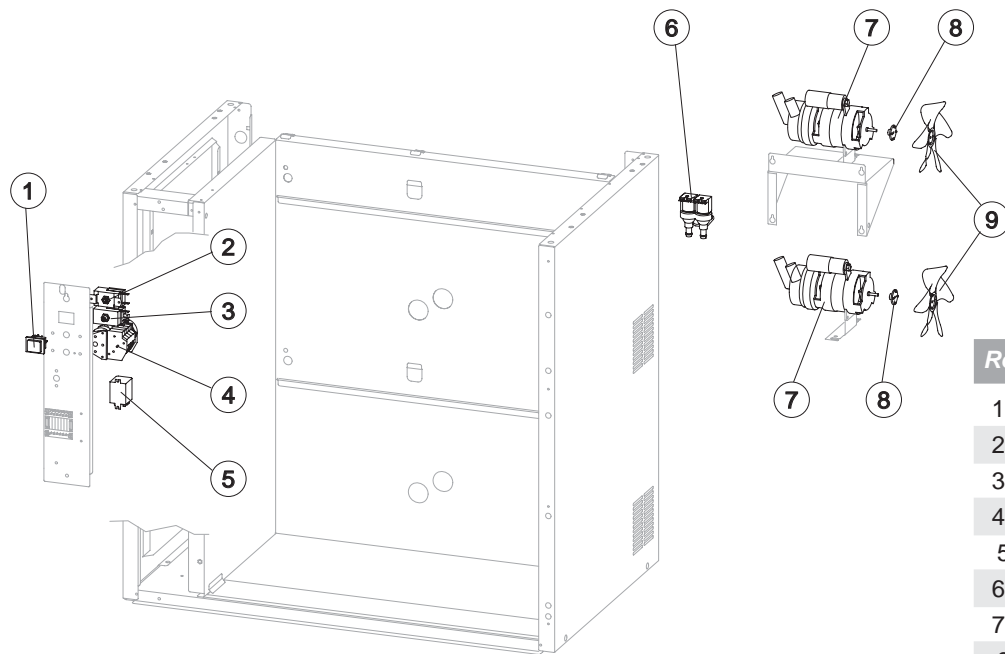

Ref.	Spare Description	Code
1*	(On-Off) Rocker Switch	23327
2*	Bin Thermostat	R23421
3*	Evaporator Thermostat	R23591
4*	Timer	see table
5	Relay	23190
6*	2 Ways-Water Inlet Valve	see table
7*	Pump Assy	C23691
8	Fan Fixing Hub	10014
9	Sucking Fan	10213

### Rif. 4\* - Timer

Voltage	Cube 18 g	Cube 33 g	Cube 13 g	Cube 42 g	Cube 60 g
T11	23247	23248	23472	23780	23922

### Rif. 6\* - 2Ways-Water Inlet Valve

Voltage	Cube 18 g	Cube 33 g	Cube 13 g	Cube 42 g	Cube 60 g
T11	23157	23784	23157	23784	23784

Rev. 0 - 04/05/2012